

Standard Knapp Standard Knapp

an EMPLOYEE owned company

LIFT TABLE REAR CASE CLAMP

UPGRADE FOR:
930, 939E, 939S, 940,
949E & 949
Casepackers

Benefits

- Positively holds cases on table as bottles enter through grid.
- Eliminates cases from moving backwards on table causing mis-alignment.
- Shortens downtime.
- Increases machine efficiency.

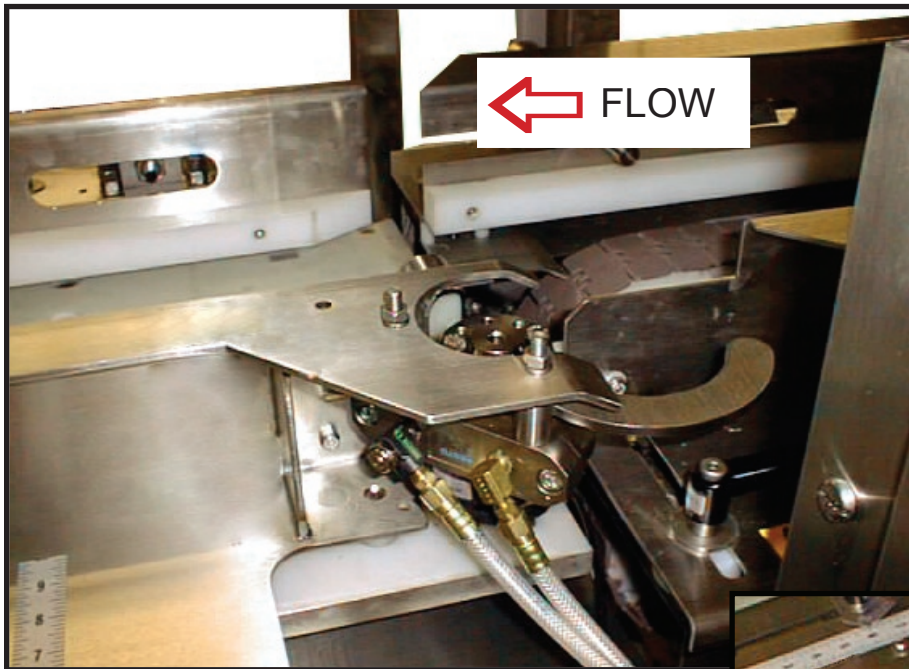

Figure 1.1 - Rear Case Clamp Installed on Machine

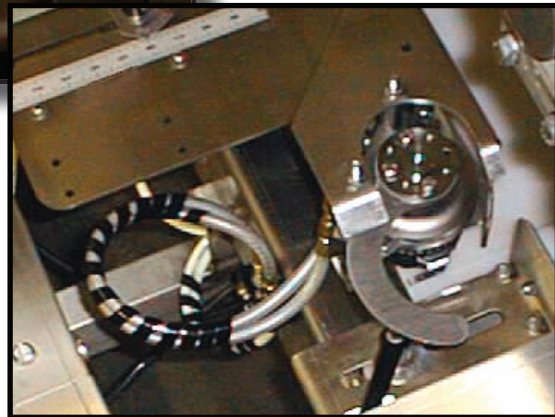

Figure 1.2 - Close-up of Rear Case Clamp

Call Standard-Knapp 1-800-628-9565 for additional information.

Standard-Knapp, Inc.
127 Main Street
Portland, CT 06480
1-800-628-9565
(fax) 860-342-0783
www.standard-knapp.com
info@standard-knapp.com

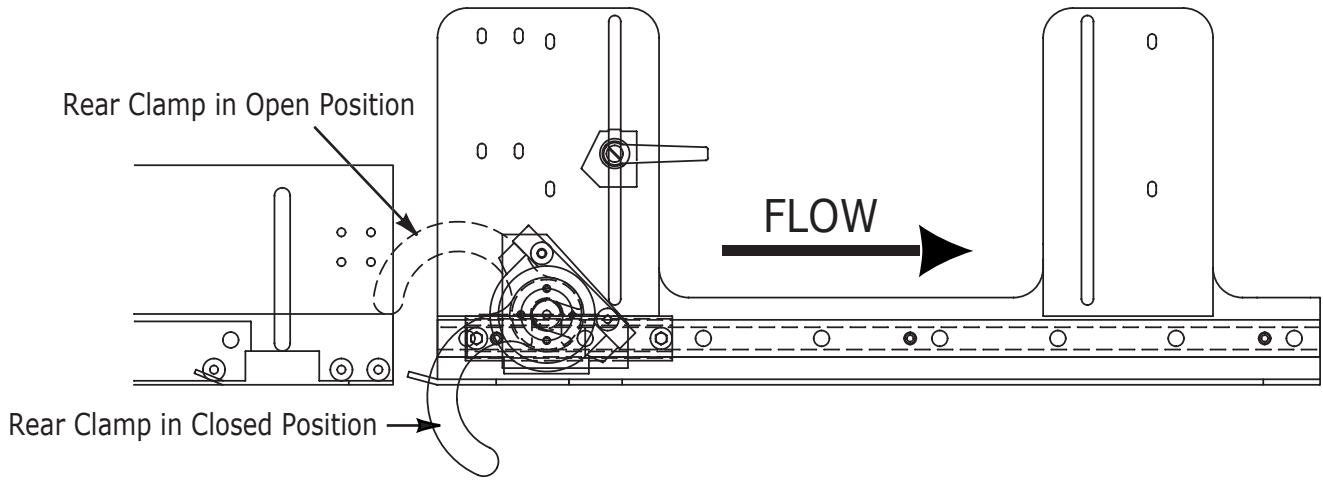
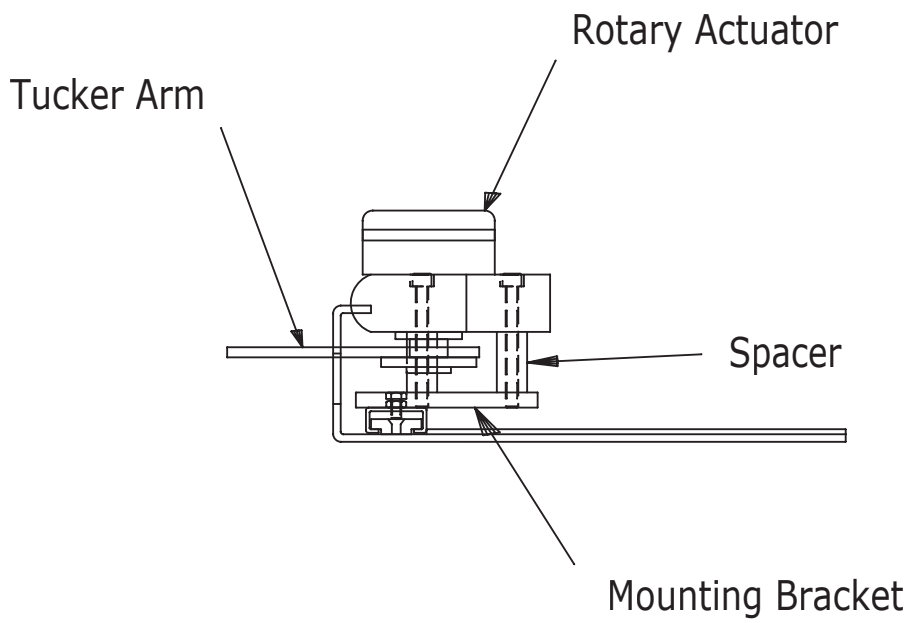

Figure 2.1 - Overhead Rear Case Clamp Shown in both Open and Closed Position



<u>SPECIFICATIONS</u>	
<u>SPEED:</u>	No Limits
<u>PRODUCT RANGE:</u>	Unchanged
<u>AIR:</u>	Additional piping required
<u>CONTROLS:</u>	Additional controls required
<u>POWER:</u>	Unchanged
<u>CONSTRUCTION:</u>	Stainless Steel, Aluminium
<u>ESTIMATED WEIGHT:</u>	5 lbs.
<u>INSTALLATION:</u>	Standard-Knapp installation recommended
<u>TIME TO INSTALL:</u>	4 Hours

Figure 2.2 - Sideview of Rear Case Clamp mounted on machine

<u>ADDITIONAL UPGRADE KITS AVAILABLE FOR YOUR CASE PACKER</u>	
• DISCHARGE ROLLER ASSEMBLY	• AIR HOSE MANIFOLD
• REAR CASE CLAMP	